

Planning a Trailhead Kiosk 2012

A Revision to *Planning a Trailhead Bulletin Board* (1998)

Table of Contents

Partners	3
Trailheads	4
Trailhead Kiosks	4
Kiosk Structure	6
Kiosk Placement	18
Kiosk Content	19
Content Elements	20
Bulletin Board	22
Panels	22
<i>Interpretive Content</i>	22
<i>Elements of Panel Design</i>	24
<i>Types of Panel Materials</i>	25
Recommended Content	26
<i>Welcome to the Appalachian Trail</i>	26
<i>Maps</i>	26
Regulatory signs	26
Basic Safety and Education	27
Optional Content	27
<i>Dynamic Content</i>	27
<i>Technology Enhancements</i>	28
<i>Local Area Map</i>	29
Keeping Kiosks Current	30
Getting To Trailheads	30
From Designated A.T. Communities™	31
At Road Crossings Without Parking	31
Appendix	32
Trailhead Kiosk Assessment Tool	32
Trailhead Design Option Templates	34
Partnership Awareness and Approval Form	36
Kiosk Content Checklist	42
Trailhead Kiosk Quarterly Review Worksheet	44
ATC Leave No Trace Posting Guidelines	45
Local Management Planning Guide, Chapter 3 (E) Sign Policy	45
Local Management Planning Guide, Chapter 3 (G) Advertising Policy	47
NPS Example	50

Planning a Trailhead Kiosk 2012

A revision to *Planning a Trailhead Bulletin Board (1998)*

The previous version of this document bulletin board referred to the structure and its function.

*This version of the document applies the following lexicon. For the purpose of this document **kiosk** refers to the superstructure, the skeleton on which the information is wrapped, like “skin”. **Panel** refers to any sets of information graphically designed with attractive visuals, printed on durable materials and mounted to the kiosk. **Bulletin board** refers to any plywood or corkboard facade built onto the kiosk, intended for standard signs, or dynamic and frequently updated content. This document recommends that a framed, hinged, and locked cover of transparent material (like Plexiglas® or Lexan®) is used to secure the applied panel(s) or bulletin board against vandalism or unwanted posts.*

This document is a tool for ATC and A.T. clubs to use collaboratively with land managers to initiate the creation new Trailhead kiosks or to review, rehabilitate, or maintain existing ones.

Partners

Cooperative management is at the heart of the Appalachian Trail. This type of management considers input and accrues value from a number of partners working together. Trailhead kiosk projects offer the same potential.

Partners for these projects include the local Trail club, one or more federal or state agency partners, ATC, and may also include nearby designated A.T. Communities™. The key group is the landowning agency at the kiosk location, or who hosts the A.T. immediately adjacent to the Trailhead (recognizing that state or local highway jurisdictions may own Trailhead parking areas).

Each club should have a policy for dealing with signs as part of the local management planning guides.

This guide is meant to reconcile the diverse management needs of various regions, the requirements of land management partners, and the unique perspective of the clubs, while emphasizing consistent communication and a few key graphic elements.

A few options are provided to deliver consistency, but these are not required elements of a design. They are offered as optional components that may be incorporated into designs at the discretion of cooperative management partners to improve the visitors' experience.

This guide does not supplant existing design and interpretive schemes employed by the Trail segment partners. Each project will engage local planners, writers, and designers to produce signs to best suit the needs and budget for the project at hand.

Please use the Partnership Awareness and Approval Form found in the appendix from the outset of the project to ensure partner awareness, potential participation, and approval of the final product.

Trailheads

There are different levels of Trailheads, or access points to the Appalachian Trail.

Not all access points to the Trail are Trailheads, but all Trailheads provide access to the Trail. Access points without adequate parking, for instance, do not lend themselves to the category of Trailhead addressed in this document.

Among the Trailheads discussed herein, there are a variety of factors that impact the category of Trailhead and the need for a Trailhead kiosk, including visitor use, road access and traffic, available parking, safe means of ingress and egress from parking area, proximity to designated A.T. Community™, and visibility from the road.

Trailhead Kiosks

Trailhead kiosks serve a variety of functions. They formalize the setting of a Trailhead, and serve as the first and last impression. Trailheads indicate arrival, welcome visitors, and provide them with information that may be essential to their safety and enjoyment on the Trail. It offers the opportunity to educate and communicate a variety of information as a means of helping to solve management problems associated with visitor use. The value of informed visitors is less waste, more reverence, and an understanding of volunteer efforts.

A Trailhead kiosk sets the stage for Trail visitors. It invites them to experience the Trail's setting, even if they never take a hike. The idea of the Trail, its length and complexity may capture the imagination of even a casual visitor who may feel encouraged to return with adequate preparation to enjoy the Trail.

In addition to creating a visible connection between the primitive footpath and the developed road for visitors arriving by car, hikers traveling long distances along the Trail itself may find information at Trailhead kiosks helpful in understanding

their location in relation to area surroundings, such as their location within county or proximity to a nearby town's available services.

A few (optional) uniform design elements offer the opportunity to provide consistency for visitors arriving from A.T. Communities™ or those visiting more than one Trailhead. (Note that a similar kiosk document has been developed for designated A.T. Communities™ to establish consistency among them as well).

A few unifying elements will help visitors recognize they are entering the Appalachian National Scenic Trail and starting a very special experience. If the site for your kiosk is located on land owned by a state or federal agency, there may be alternate or additional specific design guidelines that must be followed. For example, federal partners restrict the listing of specific business names on maps or bulletins, but permit icons representing kinds of services found nearby.

If you plan to post dynamic and changing content to a secured bulletin board as part of your kiosk, it may provide information about upcoming nearby community events and service providers, or it may be maintained by a local school or youth group to highlight the role of the A.T. as an asset to their community. (See the section about dynamic content on page 27.)

Not every site where the Trail crosses a road is a good candidate for a kiosk. The goal is to strike a balance between inviting appropriate use of the Appalachian Trail by posting relevant information and avoiding "sign pollution" created by posting too much visual clutter. In some cases a kiosk can consolidate signage at Trailheads by bringing them under one roof.

A Trailhead kiosk is best placed in a location where we want to say to the public: "Come on in! This is the Appalachian Trail, it's here for you, and here's what you need to know to enjoy it and protect it!"

The trailhead assessment tool found in the appendix will help clubs and partners prioritize the importance of Trailhead kiosk installation or an information review and update.

Remember: If cooperative management partners identify the need for a Trailhead kiosk on federal lands an environmental assessment and NEPA approval will be required before construction can begin.

Kiosk Structure

Appalachian Trail Design Construction and Maintenance suggests that a kiosk should be a fairly substantial structure of large, rough-cut wood with wood-shake, overhanging roof as a means of protecting the sign, drawing visitors in to read, commanding attention as a destination, and providing cover for visitors in bad weather.¹ This structure conforms to the natural background to be in harmony with backdrop of the A.T.; however, in some cases an alternative design may be best since a prefabricated upright aluminum or steel-framed panel are more vandal resistant, though possibly more expensive.

The type of kiosk that you choose should blend in with the setting of the Trailhead and reflect the “theme” of the Trail that the Trailhead serves. A remote Trailhead leading to a section of the Trail through deep backcountry would be ill-served by a large modern installation of aluminum and glass. Conversely, a structure of wood, with wood shingles, and no protective cover over the face of the signs would be a poor choice in a lot where the last kiosk was defaced and eventually burned to the ground. Visitors expect a bulletin board at a remote Trailhead or along the footpath of the A.T. to be rustic. And, at a Trailhead near a metropolitan area or with a prior history of vandalism, visitors can still obtain important information from an aluminum or steel and Plexiglas® kiosk. Even if it isn’t the most attractive structure available, it’s better than one that is rendered useless every six months.

The three sets of blueprints that are attached depict three different kiosks: a heavy-duty, “long-lasting” standard kiosk; a more traditional, “economic” standard kiosk; and a “vandal-resistant” kiosk. As their names suggest, each has its advantages and disadvantages. The “long-lasting” standard bulletin board is solid, durable, and expensive; the “economic” version is less imposing and uses materials that cost significantly less, but that may not last as long; and the “vandal-resistant” kiosk may discourage vandalism but is not as rustic as the other boards.

These plans are examples only, and may be adapted in any way that you feel is appropriate to fit the site and local agency requirements for your kiosk. Here are some additional factors you may want to take into account:

Structures covered by a roof convey more of a “presence,” are more convenient, are more protected from the elements, and can be more attractive than an uncovered design. Also, a roof over the kiosk draws the visitor into the shelter of the overhang – even in fair weather. On the other hand, roofed kiosks are more susceptible to vandalism and may be overkill at a little-used gravel parking lot for six cars.

The use of native, or at least less visibly treated or processed, materials can set the tone for a wilderness setting or remote section of Trail. In such a case, whole

trees, peeled or even with the bark intact for rot-resistant species (such as locust or white oak), can provide a massive, rustic feel. Even in less remote areas, use of large post-and-beam timbers give a feel of permanence, quality, stability (even to the point of lending the authority-of-the-resource to the information posted there). Even if rough-hewn native materials are not possible, rough-cut beams and dimensional lumber from a sawmill may achieve the same effect. In addition, milled lumber may be more convenient to work with and possibly cost less in the long run.

The more likely it is that vandalism will occur, the more you should tip the balance to vandal-resistant materials (such as steel, aluminum, or sturdy plastics) and move toward simpler designs where there is less to vandalize.

Roofing materials can follow the same theme as the rest of the design. Split-oak shingles complement rough-cut or native materials and, when properly installed, are a durable roofing material. Sawn shingles are easier to install, but less durable and a step back from a pure “rustic” look. However, all wood shingles are easy targets for vandalism. (Note: Do not install wood shingles over plywood or other closed sheathing! For wood shingles to last, they must be installed over sheathing with open spaces, so that they can dry out from the bottom. They should also be installed with a triple overlap.) A copper flashing will create a copper wash over wood shingles, making them more resistant to mold and mildew. If you have questions about installing wood shingles for a watertight, durable roof, contact a member of ATC’s field staff or a local roofer for advice.

Asphalt or fiberglass roofing shingles, are often short-lived, not particularly attractive, and subject to the same type of vandalism as wood. If a wood-shingle roof won’t suit your purposes, try a metal roof. Today, metal roofing material is available with baked-enamel finish. A little checking around will get you sheets that are an earth-tone color with a flat, non-reflective finish. These roofs are durable, easy to install and repair, and unobtrusive. This type of roofing is installed with color-matched screws over skip sheathing. (Note: do not use aluminum screws with tin roofing material.) Again, for more detailed advice, contact an ATC field office.

Finally, consideration should be given to protecting the posted information from weathering, theft, and vandalism. Two materials are widely used. One is Plexiglas®; the other is called Lexan®. Plexiglas® tends to become brittle and crack with time and in cold temperatures. It also turns cloudy over time. Both of these characteristics intensify if the bulletin board is situated in full sunlight. Lexan® is more durable, does not become brittle or cloudy over time, and is tougher to crack or break; but, as you might expect, it is also more expensive. If you can afford it, the extra expense of Lexan® is worth it in the long run. Both materials are available in various thicknesses. The thicker the material is, the more durable it will be. Neither, unfortunately, is completely vandal-proof. Both will melt and eventually burn if heat (such as a disposable lighter) is applied, and

neither will withstand a direct blow by a large rock. Still, they will hold up well against minor blows or scratches. You might consider mounting the Plexiglas® or Lexan® in a frame on hinges (like a door), so that changes can be made easily. A lock can be used to control what is posted on the kiosk; otherwise you may find advertisements for yard sales or local businesses posted on the bulletin board. (Additionally, those types of posted advertisements are prohibited. See the Advertising Policy in the Appendix. If the local agency partner has authorized the maintainer, s/he should remove any unauthorized ad hoc advertising, such as hand-notices, business cards, and notes; and contact the vendors that such advertising is prohibited on public land.)

RECOMMENDED BY:
 APPALACHIAN TRAIL CONFERENCE
 NPS APPALACHIAN TRAIL PROJECT OFFICE

DESIGN #1
 LONG LASTING
 BULLETIN BOARD

PRODUCTION:
 DESIGNED BY: C. MURPHY, L. GORTAL
 CHECKED BY: V. VALLINS, B. DODD
 FILE NO./DATE: 3004 2/27/78

MODIFIED BY: V. VALLINS
 DRAWN BY: C. MURPHY
 CHECKED BY: V. VALLINS, B. DODD
 FILE NO./DATE: 3004 2/27/78

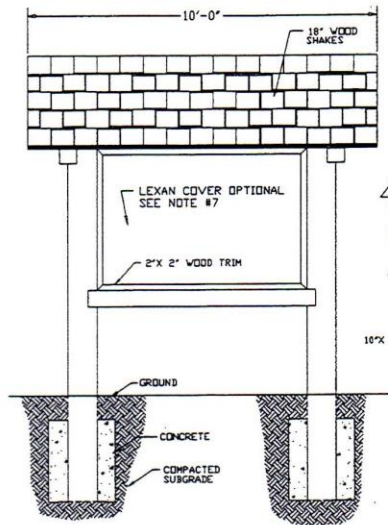

FRONT ELEVATION
 SCALE: 3/4" = 1'-0"

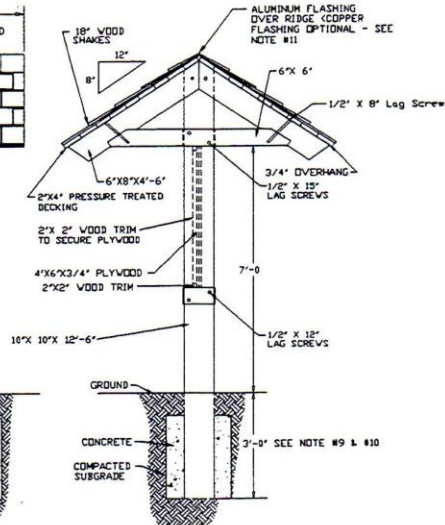

END ELEVATION
 SCALE: 3/4" = 1'-0"

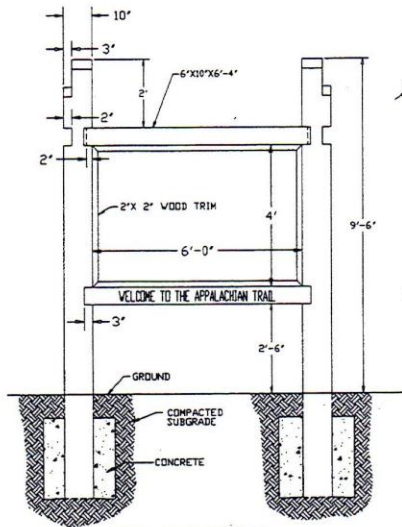

FRAMING DETAIL
 SCALE: 3/4" = 1'-0"

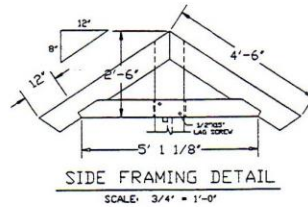

SIDE FRAMING DETAIL
 SCALE: 3/4" = 1'-0"

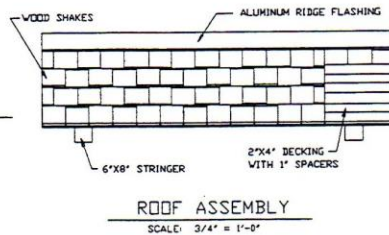

ROOF ASSEMBLY
 SCALE: 3/4" = 1'-0"

NOTES:

1. ALL WOOD SHOULD BE PRESSURE TREATED.
2. ALL HARDWARE AND NAILS SHALL BE GALVANIZED.
3. CEDAR WOOD SHAKES SHOULD BE APPROXIMATELY 18" X 1/2" HANDSPLIT WITH A 5 1/2" EXPOSURE.
4. FINISH SHOULD BE NATURAL.
5. STANDARD SLAT SIGN SHOULD HAVE APPROXIMATELY 2" LETTERS - "WELCOME TO THE APPALACHIAN TRAIL", WOOD ROUTED OR WHITE REFLECTIVE PAINT.
6. EASE ALL EXPOSED EDGES.
7. LEXAN COVER FOR PLYWOOD IS OPTIONAL. ATTACH 2" X 2" WOOD TRIM TO OUTSIDE EDGE OF LEXAN WITH 1/4" LAG SCREWS. ATTACH LEXAN TO PANEL AT TOP WITH 3" X 3" HINGES (OR COMPARABLE SIZE DOOR HINGES).
8. OPTIONAL: 5/8" REBAR MAY BE ATTACHED TO BACK OF 10" X 10" SUPPORT POSTS TO DETER VANDALS.
9. IN NORTHERN LOCATIONS, SINK SUPPORT POSTS TO A MINIMUM DEPTH OF 4'.
10. IF CONCRETE WILL NOT BE USED AROUND SUPPORT POSTS (FOOTERS), INCREASE DEPTH AN ADDITIONAL 1'0".
11. OPTIONAL: USE COPPER FLASHING EXPOSED 1" ON EITHER SIDE FROM UNDER SHAKE CAP. (COPPER WASH ON ROOF HELPS PREVENT MOLD AND MILDEW)

(NOT TO SCALE)

Appalachian Trail Gateway Bulletin Board

**Materials List
Long-Lasting Bulletin Board
Design #1**

# Needed	Material	Approximate Cost
2	10" x 10" x 12'6" pressure treated lumber (support posts)	400.00
4	6" x 8" x 4'6" pressure treated lumber	220.00
2	6" x 6" x 5' pressure treated lumber (rafters)	50.00
2	6" x 10" x 6'4" pressure treated lumber (horizontal beams)	135.00
1	6' x 4' x 3/4' plywood panel	28.00
1	6' x 4' x 1/4" Lexan®	240.00
2	2" x 2" x 4' pressure treated board (panel frame)	7.00
2	2" x 2" x 6' pressure treated board (panel frame)	7.00
1	15" (minimum) x 10' aluminum ridge flashing	27.00
approx. 18 as needed	2" x 4" pressure treated boards (roof frame) Wood shakes, triple overlay, approx. 5" – 6" exposed (100 sq. ft.)	70.00 600.00
12	1/2" x 12" lag screws	60.00
18	1/4" x 4" lag screws (panel frame)	18.00
8	1/2" x 10" lag screws	40.00
2	5/8" x 3' rebar minimum (optional; to attach to back or side of posts to deter vandals from using chainsaw on support posts)	13.00
as needed	Galvanized nails to attach 2" x 4" roof frame	5.00
as needed	Galvanized nails to attach wood shakes on roof	5.00
12	60-pound bags of ready-mix concrete (optional; can be poured dry or wet around base of support posts to add stability)	50.00
8	12" bridge spikes or lag bolts (optional: can be pounded or nailed near base of support posts, below grade, to add stability)	7.00
Total Cost		\$1,982.00

Note: Costs are estimates only, based on 2012 pricing; prices may vary significantly by locale.

Note: Larger-dimension lumber may have to be special-ordered from a sawmill.

Note: Taxes are not included in this estimate.

RECOMMENDED BY:
 APPALACHIAN TRAIL CONFERENCE
 NPS APPALACHIAN TRAIL PROJECT OFFICE

DESIGN #2
 ECONOMIC
 BULLETIN BOARD

PRODUCTION:
 DRAWN BY: E. MOSELEY, L. GUYTON
 CHECKED BY: L. GUYTON
 FILE NUMBER: 388A-10228

DESIGNED BY: V. MILLER
 CHECKED BY: V. MILLER, B. BENT
 FILE NUMBER: 388A-10228

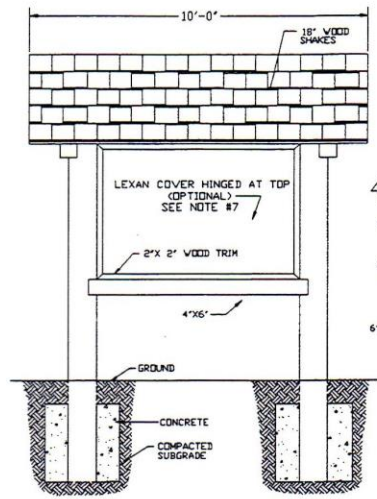

FRONT ELEVATION

SCALE: 3/4" = 1'-0"

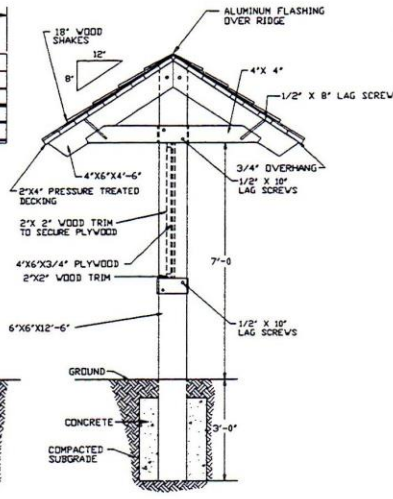

END ELEVATION

SCALE: 3/4" = 1'-0"

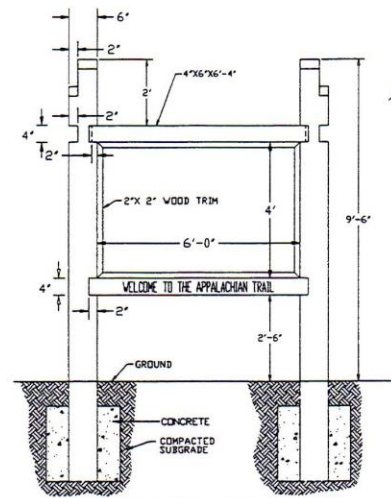

FRAMING DETAIL

SCALE: 3/4" = 1'-0"

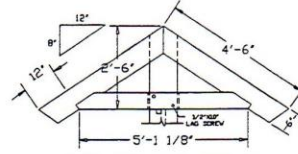

SIDE FRAMING DETAIL

SCALE: 3/4" = 1'-0"

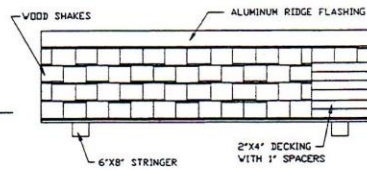

ROOF ASSEMBLY

SCALE: 3/4" = 1'-0"

(NOT TO SCALE)

NOTES:

1. ALL WOOD SHOULD BE PRESSURE TREATED.
2. ALL HARDWARE AND NAILS SHALL BE GALVANIZED.
3. CEDAR WOOD SHAKES SHOULD BE APPROXIMATELY 18" X 1/2" HANDSPLIT WITH A 5 1/2" EXPOSURE.
4. FINISH SHOULD BE NATURAL.
5. STANDARD SLAT SIGN SHOULD HAVE APPROXIMATELY 2" LETTERS - "WELCOME TO THE APPALACHIAN TRAIL". WOOD ROUTED OR WHITE REFLECTIVE PAINT.
6. EASE ALL EXPOSED EDGES.
7. LEXAN COVER FOR PLYWOOD IS OPTIONAL. ATTACH 2" X 2" WOOD TRIM WITH 1/4" LAG SCREWS.
8. OPTIONAL: 5/8" REBAR MAY BE ATTACHED TO BACK OF 10"X10" SUPPORT POSTS TO DETER VANDALS.
9. IN NORTHERN LOCATIONS, SINK SUPPORT POSTS TO A MINIMUM DEPTH OF 4'.
10. IF CONCRETE WILL NOT BE USED AROUND SUPPORT POSTS (FOOTERS), INCREASE DEPTH AN ADDITIONAL 1'.
11. OPTIONAL: USE COPPER FLASHING EXPOSED 1" ON EITHER SIDE FROM UNDER SHAKE CAP. (COPPER WASH ON ROOF HELPS PREVENT MOLD AND MILDEW)

Appalachian Trail Gateway Bulletin Board

**Materials List
Economic Bulletin Board
Design #1**

# Needed	Material	Approximate Cost
2	6"x 6" x 12'6" pressure treated lumber (support posts)	70.00
4	4" x 6" x 4'6" pressure treated lumber	60.00
2	4" x 6" x 5' pressure treated lumber (rafters)	30.00
2	4" x 6" x 6'4" pressure treated lumber (horizontal beams)	30.00
1	6' x 4' x 3/4' plywood panel	28.00
1	6' x 4' x 1/4" Lexan®	240.00
2	2" x 2" x 4' pressure treated board (panel frame)	7.00
2	2" x 2" x 6' pressure treated board (panel frame)	7.00
1	15" (minimum) x 10' aluminum ridge flashing	27.00
approx. 18 as needed	2" x 4" pressure treated boards (roof frame)	70.00
	Wood shakes, triple overlay, approx. 5" – 6" exposed (100 sq. ft.)	600.00
12	1/2" x 10" lag screws	60.00
18	1/4" x 4" lag screws (panel frame)	18.00
8	1/2" x 8" lag screws	24.00
2	5/8" x 3' rebar minimum (optional; to attach to back or side of posts to deter vandals from using chainsaw on support posts)	13.00
as needed	Galvanized nails to attach 2" x 4" roof frame	5.00
as needed	Galvanized nails to attach wood shakes on roof	5.00
12	60-pound bags of ready-mix concrete (optional; can be poured dry or wet around base of support posts to add stability)	50.00
8	12" bridge spikes or lag bolts (optional: can be pounded or nailed near base of support posts, below grade, to add stability)	7.00
Total Cost		\$1,351.00

Note: Costs are estimates only, based on 2012 pricing; prices may vary significantly by locale.

Note: Larger-dimension lumber may have to be special-ordered from a sawmill.

Note: Taxes are not included in this estimate.

RECOMMENDED BY:
 APPALACHIAN TRAIL CONFERENCE
 NPS APPALACHIAN TRAIL PROJECT OFFICE

DESIGN #3
 VANDAL RESISTANT
 BULLETIN BOARD

PRODUCTION:
 KNOWN BY:
 PAGE 1 OF 3

DESIGNED BY:
 DRAWN BY:
 CHECKED BY:
 DATE:

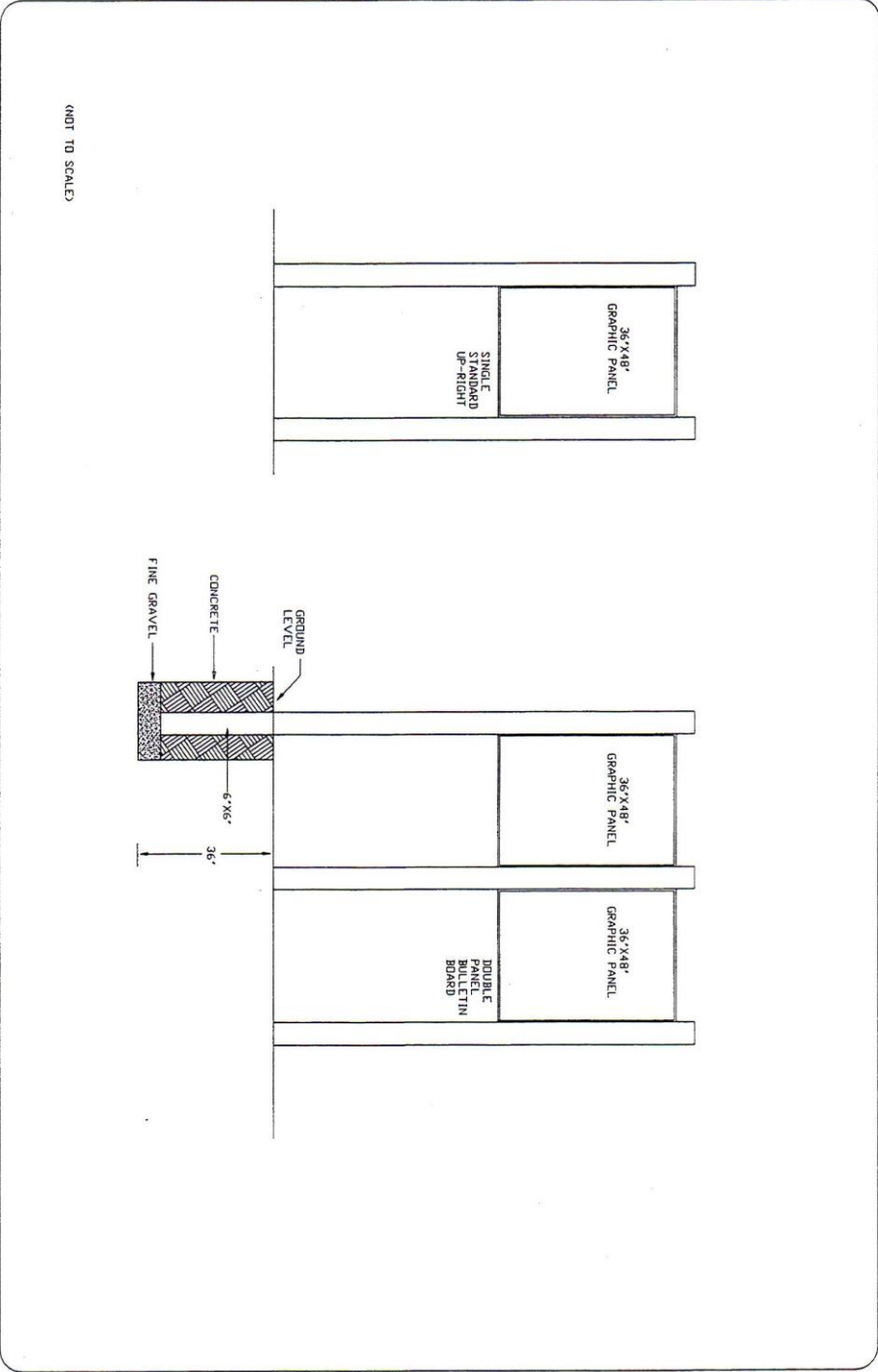

Appalachian Trail Gateway Bulletin Board

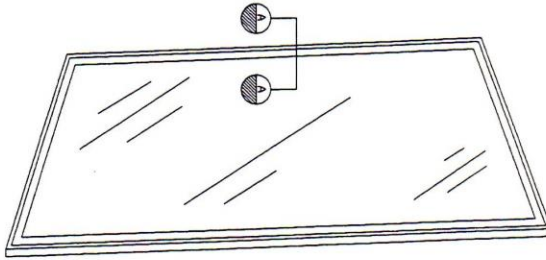

(NOT TO SCALE)

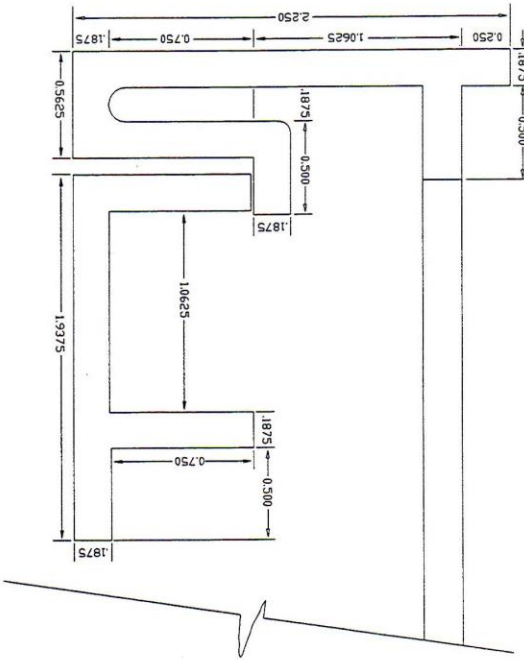

PLAN-SECTION AA
CASE MOLDING

RECOMMENDED BY:
APPALACHIAN TRAIL CONFERENCE
NPS APPALACHIAN TRAIL PROJECT OFFICE

DESIGN #3
VANDAL RESISTANT
BULLETIN BOARD

PRODUCTION
REVISED BY: JEFFREY W. ...

DESIGNED BY: V. YELSON
DRAWN BY: G. RAYNE
CHECKED BY: V. YELSON, L. BOCK
FILE NUMBER: MATHEN 22723

PAGE 2 OF 3

Appalachian Trail Gateway Bulletin Board

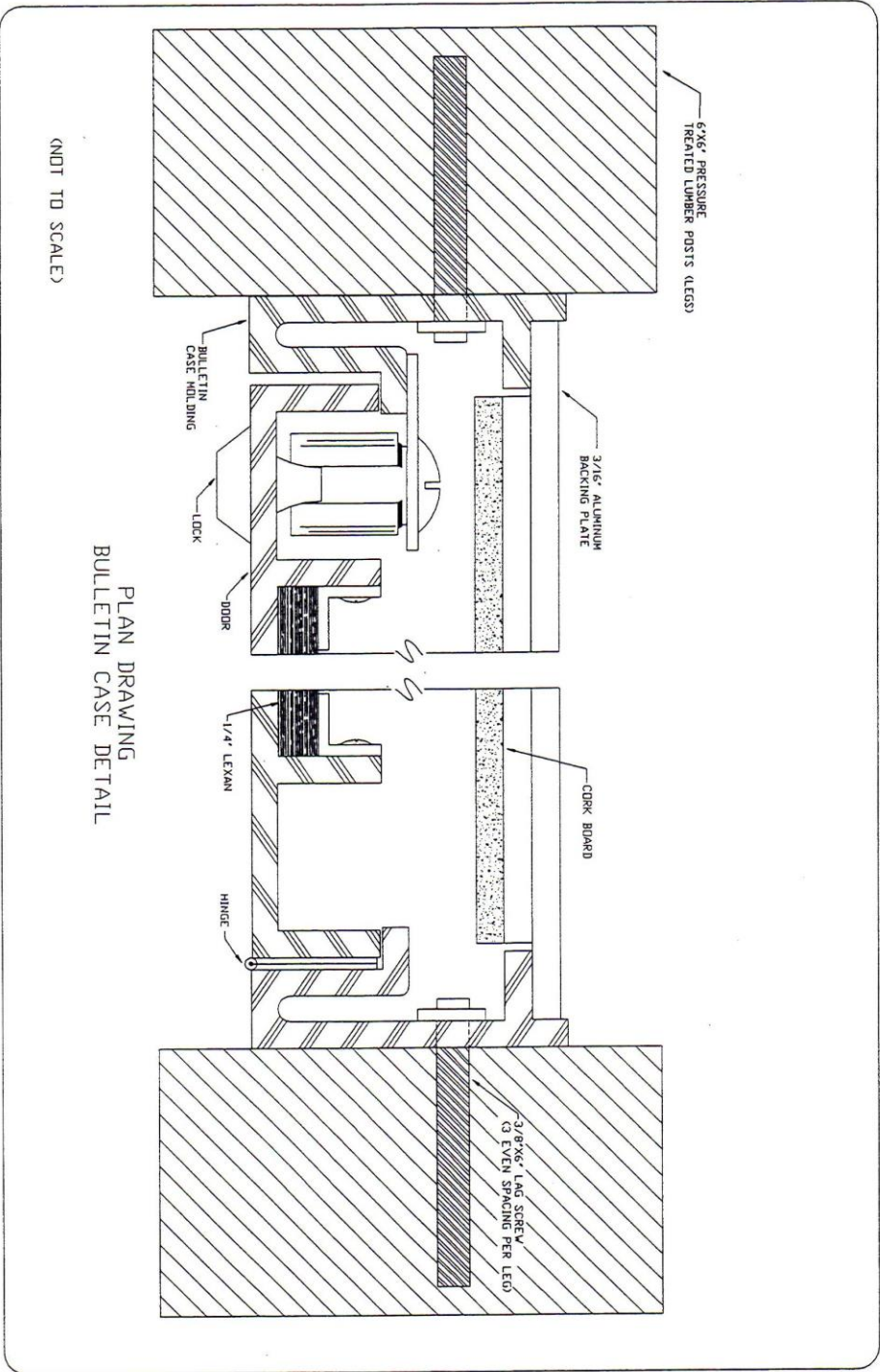

RECOMMENDED BY:
 APPALACHIAN TRAIL CONFERENCE
 NPS APPALACHIAN TRAIL PROJECT OFFICE

DESIGN #3
 VANDAL RESISTANT
 BULLETIN BOARD

PRODUCTION:
 DESIGNED BY: JEFFREY W. S.
 PAGE 3 OF 3

MODIFIED BY: V. VAHREN
 DRAWN BY: G. M. BAKER
 CHECKED BY: V. VAHREN, B. STEIN
 FILE NUMBER: 3110 31147/28873

Appalachian Trail Gateway Bulletin Board

Materials List
Vandal-Resistant Bulletin Board
Design #3

Single Upright Panel Bulletin Board

<u># Needed</u>	<u>Material</u>	<u>Approximate Cost</u>
1	36" x 48" single standard upright panel bulletin board	\$800.00
12	60-pound bags of ready-mix concrete	\$35.00
Total Cost:		\$835.00

or:

Double Upright Panel Bulletin Board

<u># Needed</u>	<u>Material</u>	<u>Approximate Cost</u>
1	36" x 48" double upright panel bulletin board	\$1000.00
18	60-pound bags of ready-mix concrete	\$50.00
Total Cost:		\$1050.00

note: costs based on special-order through ATC; arrangements should be made through the regional office for your area.

Kiosk Placement

If vandalism is not a concern, a Trailhead kiosk can be installed so that it is immediately adjacent to the Trailhead parking lot. Two-sided boards (which provide you with lots of space to display information) are more effective if they are installed so that they project into the parking lot at a 90° angle, so that both sides can be seen in the lot.

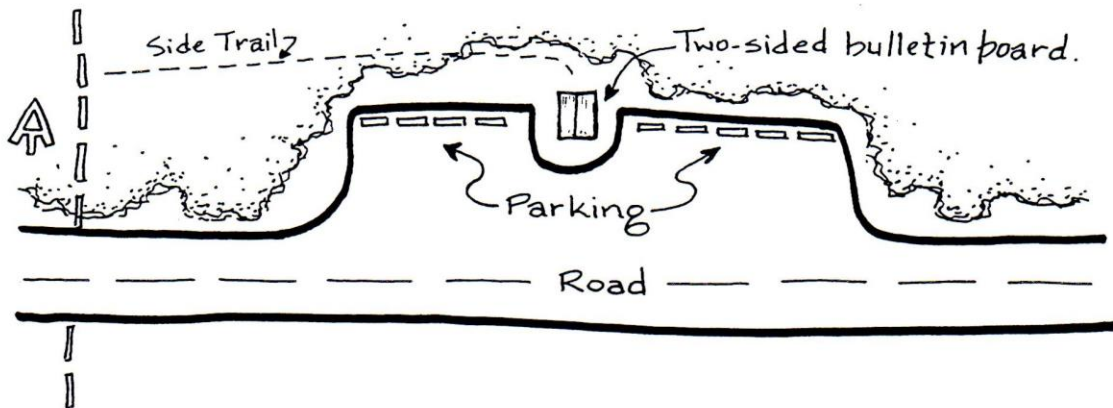

If you intend to use only one side, then the kiosk can be installed so that the operative side faces the users. The other side would normally be blank and may be inaccessible (for example, facing the parking area and installed backed up to the vegetation at the edge of the lot). It is important to remember that a kiosk should not present a hazard to traffic in the lot and should be protected from vehicles with rock, log, or prefabricated-concrete curbing.

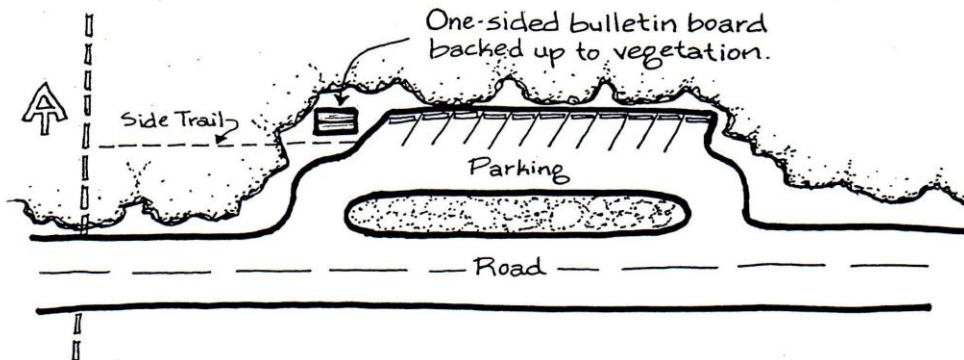

At locations that are prone to vandalism, ATC recommends partnering with a school or youth group to maintain the kiosk. Evidence suggests that kiosks prone to vandalism, once adopted by students, are less vandalized. As a precaution,

original art from students should not be posted directly, but scanned, printed, then posted so that the content can be mounted again quickly.

If no other option is available for locations prone to vandalism, the kiosk may be installed back in the woods at some distance from the parking lot so that it is not visible to the casual parking-lot user or cruiser. It is important that the kiosk not be too far from the lot if it contains messages that should reach visitors before they are far from their vehicle. There are effective Trailhead kiosks along the Trail that are located up to one-half mile from the Trailhead parking lot.

Normally, however, the kiosks are located a few hundred yards from the parking lot – not too far for a hiker to turn back, but far enough to discourage someone who may be less interested in hiking and more interested in vandalism.

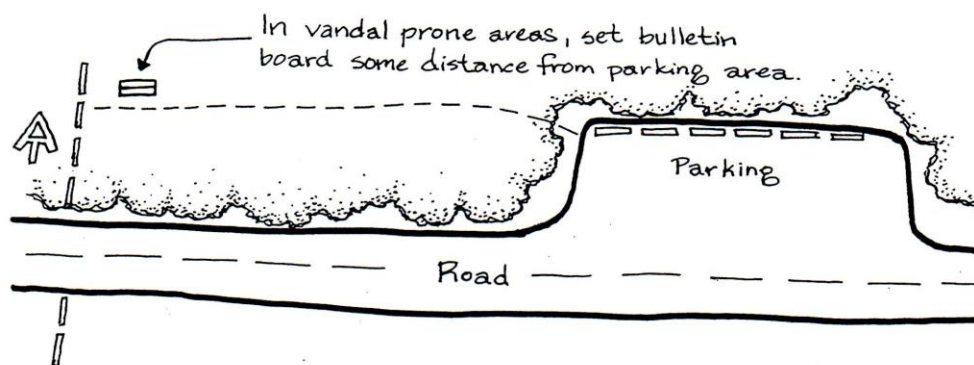

Kiosk Content

Kiosk panels and bulletin boards offer a great way to consolidate relevant signs and information, and reduce or prevent sign pollution in the backcountry. They can be used in combination with a bulletin board, with the panel utilizing one-half of one-side of a 4' x 6' kiosk; in this example the panel is 24" X 36". A panel can also be designed as one side of a two-sided kiosk.

Keep these simple tips in mind when planning your kiosk panels or bulletin board posts since most people only look at a message for 11 seconds:

- Keep it brief
- Make it easy to read by using Arial font at a large point size since most people stand about four feet from a sign.
- Use an active voice.
- Simplify the message so it's easy to understand.
- Make sure it's relevant.
- Use graphics, if possible, to enhance your message.

As a rule, avoid acronyms, adverbs, contractions, clichés, and colloquialisms.

Emphasize appropriate use with “Hikers Welcome” and “Walkers Welcome” invitations, and utilize regulatory signs and symbols that convey uses that are restricted, such as biking or horse riding.

A “Kiosk Content Checklist” is provided in the appendix to assist you in planning where information will be displayed on the kiosk.

Content Elements

These are the types of content elements that make up most A.T. Trailhead kiosks. They are discussed in more detail, as needed, in the sections that follow.

Content Element	Purpose or Message
Appalachian Trail	Preferably a header along the top of the panel or bulletin board, or a routed wood sign mounted to the kiosk that indicates arrival at the Appalachian Trail.
Welcome to the Appalachian Trail	Describes the A.T. and captures the imagination of the visitor by providing approximate mileages to Springer and Katahdin. This may also explain how the Trail is marked.
Map(s)	At a minimum a map of the A.T. in the area, including topography, a “you are here” indicator, the location of the Trail, other trails, Trail features, and Trail profile. Other maps posted may include an overview map of the whole A.T. or a map representing the Trail in the context of the surrounding communities or county and their available services.
Emergency Contact	Information includes instructions to dial 911 and provides other local emergency services in bold print. It may also include information on how to communicate location.
Who Manages the Trail?	This element graphically describes the cooperative management system, utilizing partner logos, describing roles, conveying basic information, and contact information.
Regulatory Signs	Signs indicating specific prohibitions for the A.T., its corridor lands, or other local restrictions. These signs need approval from the local land-managing agency since reference to pertinent regulation must be

	included on sign(s) to be properly enforced.
Basic Safety/Education	These signs may be anything related to health and safety, including a simple list of preparations, precautions, water treatment advisory, animal awareness, or weather-related alerts particular to this location.
Basic Trail Description	This sign provides information about two to three local destinations (rivers or summits) or hikes in either direction that include a brief description, difficulty, and estimated time needed for hike. (To minimize vandalism and vagrancy, it is recommended that distances to shelters not be given at Trailheads.)
Leave No Trace	ATC updated its Leave No Trace posters in 2012 to succinctly explain LNT principles to visitors. Guidelines for posting LNT signs are found in the appendix.
Interpretive Information	These elements may provide information on local geology, history, natural history, or other Trail features. They may introduce conservation or land management strategies taking place in the area (MEGA-Transect monitoring, exotic-invasive plant removal and restoration, etc).
Technology Enhancements	A QR (quick response) Code offers a quick link to additional and less-essential information about this site or nearby resources and is an optional component.

Depending on your preference for posting information to a bulletin board or a combination of a bulletin board and panel, you will mix and match content elements. Certain elements work better as bulletin board material, such as Leave No Trace posters, regulatory signs, and safety or educational information. [Appendix N](#) of the A.T. Local Management Planning Guide is a catalogue of Trail management signs available from ATC.

An introduction to the A.T., a basic Trail description, information on who manages the Trail, and interpretive information is well suited for a panel. As content elements, maps work well posted to bulletin boards or worked into the design of a panel.

Bulletin Board

Bulletin boards offer the chance to share information specific to a certain area. Visitors will not spend lots of time reading all pieces of information posted here, so your primary message needs to “pop.” Remember to leave plenty of open space between signs so they are not crowded; this will make the messages easier to read. If you’re considering using a smaller single-panel vandal-resistant design, you may need to reduce the size of the signs or remove some of the information to present only the most critical information.

Panels

ATC recommends considering a designed panel as part of your Trailhead kiosk. This type of graphically designed display makes a visually interesting destination to draw visitors in and convey Trail information. Panels offer an exciting chance to showcase the Trail because they can be display images from the Trail that may entice visitors to take a hike.

If you decide to use a panel as part of your kiosk, ATC can offer a template for your use, or provide you with graphic elements you can incorporate into your own design.

ATC strongly encourages the use of Arial font for text and colors that reflect the guidelines provided to A.T. Communities for their kiosks.

As a general rule, paragraphs or blocks of text should be no longer than 4–6 sentences.

Interpretive Content

The primary purpose of a Trailhead kiosk is a practical way to convey the Trail information; the second purpose is interpretation – telling the story of the A.T. experience at that location.

The primary purpose of interpretation is to foster conservation values by assisting the visitor in developing a keener awareness, appreciation, and understanding of what they are viewing or experiencing. Interpretation helps accomplish management goals by minimizing human impact by encouraging thoughtful use. Interpretive content may also help visitors understand and appreciate the work of the cooperative management partners to protect and maintain the A.T.

Partners involved in the management of the A.T. should determine potential interpretive content themes and assess the importance of conveying that content.

A basic theme can be determined by asking “What adds value to the experience at this location?”

The theme is the *one* take-home message you hope visitors to *this* Trailhead leave with on their hike and return home with at the end of the day.

Some thematic ideas to consider are listed below. The site’s corresponding landscape may offer a natural thematic fit for your panel.

Present

- Where am I?
 - Offers perspective on this site in relation to entire Trail or surrounding communities.
- Explore the A.T.
 - Voices along the Trail (Trail luminaries or volunteer voices, for example)
 - Cooperative management
- Natural Heritage
 - Flora and fauna that naturally occur in this area
 - Geology and landforms of interest

Past

- Conservation Heritage – includes efforts to preserve lands, water, cultural resources
- Then and Now
- Cultural Heritage – the surrounding area/communities and/or landscape, such as its role in American history, industrial heritage, agricultural heritage, transportation heritage
- Emerging Frontier – ancient residents, expansion/settlers, landscape

It is helpful to link the theme to an active sensory experience; an example would be smelling or feeling a particular leaf. By connecting the visitor to the tangible resource, it assists them in connecting to the “intangible” meanings that provoke learning and promote protection. This facilitates their connection with the resource on an emotional as well as an intellectual level.

Seek brevity and clarity in conveying your thematic take-home. Provoke interest with headlines. Reveal information with content, and relate to what they already know with metaphors.

A contemporary approach to bridge the recommendation in *A.T. Design, Construction, and Maintenance* with modern technology and valuable interpretive information is to use QR codes to share information on natural or cultural history in the area.

Elements of Panel Design

The elements of a panel include graphics and images, accompanying text, and a map. A few recommended elements are noted in the sample below, while other elements are simply described.



Recommended: APPALACHIAN TRAIL Header in style presented, with approximate distances to Springer and Katahdin because it tells the story of the whole Trail and serves as an inspiration.*

Area A.T. Map

Overview Map of entire A.T. may be a NPS strip map reproduced no shorter than 36" or a simplified and smaller version available from ATC.

QR Code

Recommended: Who Manages the Trail tells the story of the cooperative management system and provides contact information for the partners – Trail club(s), ATC, and land-manager agency logos.

* Use "~" in front of mileage numbers to convey approximate number of miles to Georgia or Maine.

See other template design options in the appendix of this document. See full-size versions in the separate document A.T. Trailhead Panel Templates.

Types of Panel Materials

The cost estimates provided here will help you determine which panel fabrication method is most appropriate for your budget. Other methods may be available.

Panel Fabrication Process	Description	Cost Estimate
Fused Polycarbonate: Vinyl inkjet printing fused between two sheets of polycarbonate	<ul style="list-style-type: none"> • UV resistant • Excellent color transmission • Vandal resistant • Damage to surface can often be cleaned or buffed • 30% recycled materials • ¼, ½-inch thickness available 	\$60—75 per sq. ft. at ½” thick
High Pressure Laminate: inkjet printed paper and melamine sheets compressed with high pressure and heat. As the melamine resin melts, print is absorbed to consolidate product into single solid plastic piece	<ul style="list-style-type: none"> • Excellent image quality • 30% recycled materials. 	\$60—75 per sq. ft. at ½” thick
Sintra: Moderately expanded closed-cell polyvinyl chloride (PVC) extruded to a solid sheet with low gloss, matte finish	<ul style="list-style-type: none"> • Lightweight and rigid. • Moisture and UV resistant 	\$9—12 per sq. ft.
Vinyl	<ul style="list-style-type: none"> • Very good image quality. • Easy to mount. • Easier to damage. 	\$6—10 per sq. ft.
Matte Paper Printed, laminated	<ul style="list-style-type: none"> • Fades fastest. • Last water resistant. • Easier to damage. 	\$9—12 per sq. ft.

Recommended Content

ATC strongly recommends that any kiosk include these content items:

- ANST Logo, and preferably all cooperative management partner logos (likely presented as “Who Manages the Trail”)
- Welcome to the Appalachian Trail
- Map of the Trail in the area
- Emergency Contact information
- Leave No Trace information

Welcome to the Appalachian Trail

The Appalachian Trail (A.T.) is a footpath about 2,180 miles long that goes through 14 states along the crests and valleys of the Appalachian range from the southern terminus in Georgia to the northern terminus in Maine.

Maps

Trail Map

ATC strongly recommends that, at a minimum, a section map of the A.T. in the area should be posted on the kiosk. It should include topography, a “you are here” indicator, the location of the Trail, other trails, and a Trail profile.

It’s common for day-use visitors to capture a snapshot of a map on a Trailhead kiosk with their digital camera or phone and revisit it throughout their hike if they are not carrying a map.

Trail Overview Map

ATC recommends that a map encompassing the length of the Trail is displayed to convey the magnitude of the entire Trail, so that the visitor can assess his/her location in relation to the scale of the whole Trail, connecting them with something much bigger than the short hike they may take.

ATC encourages the use of the NPS strip map, preferably at its original size of 46” long, but produced no smaller than 36”-40” tall.

If space restricts the use of the long map, an alternate, less-detailed version is available for use from ATC.

Regulatory signs

The wording of regulatory signs for specific prohibitions or the use of symbols representing prohibited activities needs to be approved by the land-managing agency; reference to the pertinent regulation must be included for it to be properly enforced.ⁱⁱ

Basic Safety and Education

Educational signs are recommended, but not required, at Trailhead bulletin boards precisely because they provide necessary health and safety information before hikers enter the backcountry. These signs may educate visitors on unusual trail or weather conditions, safety precautions, and emergency information. With this knowledge, visitors can be more prepared to adapt with more supplies or reschedule their trip.

Tips for Creating Information and Educational Signs

(adapted from *Appalachian Trail Design, Construction, and Maintenance*)

Information and educational signs require a wide range of messages and suitable letters, sizes, colors, and layout. However, some basic rules for design still apply:

- Be clear. State the sign's purpose in the heading: "Trail Relocation" or "Bears Active in Area." In the text, give information visitors need to act correctly.
- Be positive. Use a friendly tone and positive wording ("Please pack out your trash" versus "No littering.")
- Use capitals sparingly. Use capital letters only for short messages; use lower-case letters for the text.
- Use visuals. Symbols and graphics should convey and support the message.
- Use plastic or sheet metal. Lightweight plastic or sheet metal is inexpensive, easily reproduced, reasonably durable, and easy to carry and post.
- Use one font. Don't mix fonts. Please use Arial as often as possible.
- Size appropriately to catch people's attention.
- Word carefully. Avoid using the word "warning," except for serious, imminent hazards.

Optional Content

Dynamic Content

Kiosks should be designed with some amount of available space for the purpose of posting news and changing information. By nature, dynamic content is optional, but providing available space on your kiosk for this type of posting is encouraged.

Relevant information to the dynamic content portion might include:

- Alerts relevant to hikers
 - Permanent relocations (for first year after completion to eliminate confusion with old editions of guidebooks and maps)
 - Temporary hazards
 - Temporary change in the Trail's route
- Planned prescribed burns

- Special events within the community
- Volunteer opportunities, either ongoing or upcoming scheduled “events”
- Regulations & Safety information (e.g. state hunting season information)
- Other suggestions from ATC or A.T. club

At your discretion, you may chose to devote all or part of the optional bulletin board component of the kiosk to school students. School students using the Trail as a basis for learning through the Trail to Every Classroom program may be interested in helping to maintain a portion of the community kiosk as part of the service-learning component of their curriculum. Content from schools and youth groups tends to reduce vandalism at vandal-prone kiosks.

If a school adopts part of a kiosk, recommend that they scan, print and post their work rather than posting original works of art. In the event of vandalism they can quickly and easily replace their display.

Technology Enhancements

QR codes are an optional element to your design. Visitors must have a smart phone and reception to access QR information, so this can be an ephemeral unreliable means of communicating essential information.

Even if mobile phone service is reliable at a given Trailhead, not all visitors will have smart phones, so partners are encouraged to be discerning about the information provided via the landing page from the quick response link.

Work with land-managing agency to determine an appropriate destination page for the QR link.

Options for landing page information include:

- Downloads of hikes from this location
- ATC’s Plan a Hike webpage (what to you need, health and safety, regulations, LNT)
- Interpretive information
- Nearby designated A.T. Community™ events
- “Mobile Visitors Center” for nearby A.T. Community™ that may include a map and list of resources
- Questing, a virtual treasure hunt connecting the A.T. and it’s A.T. Communities™, downloadable from A.T. kiosks.
<http://discoverfrontroyal.com/page.cfm/cat/123/>
<http://www.vitalcommunities.org/valleyquest/questdir.cfm>

One caution for volunteers and land managers is to be aware of vandalism in the form of other QR Code stickers superimposed over the one included on your material.

Local Area Map

An optional map to include on a kiosk is one that represents the Trail in the context of the surrounding communities and county. It shows roads and may also list icons to services that hikers may find useful, such as groceries, convenience stores, laundry, pay phone, post office, and a hotel or hostel.

Utilizing icons creates impartiality for hiker services and increases the longevity of the map since they withstand businesses changing ownership or changing names.

This type of map may include a directory that has the names and phone numbers of businesses, so that visitors can readily verify the hours, vacancy, or operating status of a business.

Supplemental Information

Cooperative management partners may decide to design a brochure to accompany a certain Trailhead kiosk. Depending on the purpose of the brochure it may provide

- A map of a nearby community
- Hiking information on the Trail and its features, or details on planning a day hike
- Information on the club's upcoming volunteer worktrips, hikes, or club membership
- Interpretive information related to the Trail.
- Tips to Leave No Trace.

If you decide to create a brochure, follow the guidelines for sign text – keep it clear, brief and simple. Be aware that a brochure may end up as litter or used for unintended purposes, and be ready to adapt, if necessary.

Keeping Kiosks Current

Kiosks serve as an important part of setting the stage for a hiker's experience. If content is out of date, content is faded beyond legibility, or a kiosk is in disrepair, it sends a message of disregard that may result in increased littering or misuse of the Trail. It is worse to have out-of-date or disintegrating messages posted than no information posted at all.

To assure that content is current, ATC encourages section maintainers to assess kiosks several times a year to assess needs or deficiencies. Once assessed, the club can work with the respective land management agency and ATC, if necessary, to update the content or physical structure. An annual review worksheet is provided in the appendix as a resource for keeping your kiosk current.

The NPS Facilities Management Software System (FMSS) will be utilized to more comprehensively track kiosks, inspect for deficiencies for the purpose of short and long term planning, provide brief descriptions of content, and provide a picture to accompany GPS coordinates for Trailhead kiosks for future planning, updating, and assessment.

Getting To Trailheads

Helping visitors get to the Trail is an important and often overlooked aspect of the A.T. maintenance and management. This includes wayfinding from nearby communities as well as appropriate signs or kiosks upon arrival.

How do you know when you are "there"?

Because the Trail was designed and is maintained as a primitive footpath, it has often been intentionally downplayed and not promoted. However, the Trail has gained preeminent awareness nationally and internationally in the last decade, drawing more people to seek out the experience of a hike on the Appalachian Trail. (Related to this increased visitation, an informed populace is the best approach to alleviate management challenges associated with their use and underscores the need for adequate dispensation of information at Trailheads.)

Take a test drive. Drive to the Trailhead from your community. As you drive, pretend you have never been to this Trailhead before. *Would you know you are at the Trail if you hadn't been here several times each year for a number of years?*

Look at the Trailhead with a fresh set of eyes. *What indicates your arrival? Is this indicator readily visible to a new visitor? Once here, does a new hiker have information he or she needs to safely explore and enjoy the Trail?*

From Designated A.T. Communities™

Finding the Trail may be difficult for new hikers or other visitors arriving from designated A.T. Communities™.

Many A.T. Communities™ are interested in establishing a clearer “link” between their town and the Trail. Utilizing wayfinding signs will help direct people from communities to the Trail’s access point(s) at nearby Trailheads.

After assessing your road crossings, work with land managers, ATC, DOT, and A.T. Communities™ to define necessary signage to assist visitors in finding their way to the A.T. The Appalachian National Scenic Trail (ANST) logo may play a prominent role in assisting visitors in wayfinding to reach an A.T. Trailhead.

Helpful planning resources include:

- [Sante Fe National Historic Trail Road Signs Planning Suite](#)

At Road Crossings Without Parking

Where adequate parking is not feasible or desirable, it is best to mark only the entrance of the Trail with standard blazes on both sides of the road, so they are obvious to the Trail users but not to passing motorists. As long as the sign does not encourage motorists to park on the shoulder of the road, it may be appropriate to use a highway sign that identifies the Appalachian National Scenic Trail or depicts a hiker crossing to inform motorists of the presence of the Trail.

“When you believe your section of Trail needs them, ask your state or county highway department to erect two signs, one facing in either direction on the highway. You can also consult the land managing agency about erecting one of the NPS’s official A.T. signs.”ⁱⁱⁱ

Trailhead Design Option Templates

See full-size versions of vertical and horizontal templates in the separate document A.T. Trailhead Panel Templates.

Vertical

Design A

Design B

Design C

Horizontal

APPALACHIAN TRAIL
MAINE (~1,327 miles) TO GEORGIA (~854 miles)

Waynesboro VIRGINIA

Waynesboro is an Appalachian Trail Community™ recognized for its dedication to promoting and preserving the Trail.

Waynesboro offers a variety of points of interests and accommodations for hikers including showers, hotels and a hostel. We are a town where being hospitable comes naturally.

Local Points of Interest

- Waynesboro Heritage Museum
- Shenandoah Valley Art Center
- Plumb House Museum
- Accommodations for Hikers: YMCA
- Appalachian Trail Campground
- Gateway Theater

Trail Managed and Maintained by

ORGANIZATIONS UNDER THE APPALACHIAN TRAIL

In case of emergencies dial 911

Important Trail Information

Appy Trail

The Appalachian Trail (A.T.)
is a footpath about 2,180 miles long that goes through 14 states along the crests and valleys of the Appalachian range from the southern terminus in Georgia to the northern terminus in Maine.

Hiking the Appalachian Trail

- South from your location at Rockfish Gap, you will pass through an old settlement, that once had homes and terraced gardens. The Old Dominion A.T. Club maintains the A.T. and the Paul C. Wolfe Memorial Shelter in this section.
- North of here, you will be entering Shenandoah National Park. Backcountry permits are required when camping in Shenandoah National Park. The trail ascends Scott Mountain where you can overlook the town of Waynesboro (3.1 miles) and continues to Bear Den Mountain (4.5 miles) with more great views of the surrounding country. At 6.6 miles you'll reach a meadow of Little Calf Mountain.

Design A

APPALACHIAN TRAIL
MAINE (~1,327 miles) TO GEORGIA (~854 miles)

Welcome to the Appalachian Trail

The Appalachian Trail (A.T.) is a footpath about 2,180 miles long that goes through 14 states along the crests and valleys of the Appalachian range from the southern terminus in Georgia to the northern terminus in Maine.

Hiking the Appalachian Trail south from your location at Rockfish Gap, you will pass through an old settlement, that once had homes and terraced gardens. See if you can still find the cemetery for people who used to call these lands home.

The Old Dominion A.T. Club maintains the A.T. and the Paul C. Wolfe Memorial Shelter in this section. It was built by ODATC members in 1991 beside Mill Creek; Paul Wolfe was an avid outdoorsman who left a portion of his estate to the ATC for construction of the shelter. It took 30 people every weekend for two months to complete the shelter. Materials were hauled two miles by hand and tractor.

Hiking the Appalachian Trail north of here, you will be entering Shenandoah National Park. Backcountry permits are required when camping in Shenandoah National Park. The trail ascends Scott Mountain where you can overlook the town of Waynesboro (3.1 miles) and continues to Bear Den Mountain (4.5 miles) with more great views of the surrounding country. At 6.6 miles you'll reach a meadow of Little Calf Mountain.

You are near Waynesboro, an Appalachian Trail Community.

Waynesboro is an Appalachian Trail Community™ recognized for its dedication to promoting and preserving the Trail.

Waynesboro offers a variety of points of interests and accommodations for hikers including showers, hotels and a hostel. Waynesboro is a town where being hospitable comes naturally.

Local Points of Interest in Waynesboro

- The Towns District
- Shenandoah Park and Recreation
- Office of Tourism
- Public Library
- Rockfish Gap Tourist Info
- Crater Spring Park
- Shenandoah National Park
- Appalachian Trail Campground
- Waynesboro Heritage Museum
- Shenandoah Valley Art Center
- Plumb House Museum
- Accommodations for Hikers: YMCA
- Appalachian Trail Campground
- Gateway Theater

Trail Managed and Maintained by

ORGANIZATIONS UNDER THE APPALACHIAN TRAIL

In case of emergencies dial 911

Important Trail Information

Appy Trail

Additional information can be found at:

Waynesboro's Visitor Center
10018 Main Street
(540) 943-6644

Rockfish Gap Tourist Information Center
10018 Main Street, Athens, VA 22920
(540) 943-5182

Design B

Partnership Awareness and Approval Form

The shaded portions of this form should be completed as the **first** step in the kiosk project to identify the person responsible for input and approval of the kiosk panel. The remainder should be completed as the **last** step in finalizing the design.

Appalachian National Scenic Trail, Park Office

I, _____, am responsible for input in and approval of kiosk panel content, including the permission to use the agency or organization logo, and the applicability of relevant emergency contact information.
Name: _____ Title: _____
Signature: _____ Date: _____

The (name of kiosk project) has been reviewed by the Appalachian Trail Park Office.

This content of the kiosk

_____ does

_____ does not

have approval to carry the logo of the Appalachian National Scenic Trail as part of the *Trail Managed and Maintained by* information section.

Name: _____ Title: _____

Signature: _____ Date: _____

Appalachian Trail Conservancy

I, _____, am responsible for input in and approval of kiosk panel content, including the permission to use the agency or organization logo, and the applicability of relevant emergency contact information.

Name: _____ Title: _____

Signature: _____ Date: _____

The (name of kiosk project) has been reviewed by the Appalachian Trail Conservancy.

This content of the kiosk

_____ does

_____ does not

have approval to carry the logo of the Appalachian Trail Conservancy as part of the Trail Managed and Maintained by information block.

The Appalachian Trail Conservancy phone number _____

_____ should

_____ should not

appear as a resource in the event of an emergency.

Name: _____ Title: _____

Signature: _____ Date: _____

Local Land Manager (adjacent to community or at trailhead)

I, _____, am responsible for input in and approval of kiosk panel content, including the permission to use the agency or organization logo, and the applicability of relevant emergency contact information.
Name: _____ Title: _____
Signature: _____ Date: _____
Agency: _____

The (name of kiosk project) has been reviewed by the _____ (agency name).

This content of the kiosk
_____ does
_____ does not
have approval to carry the logo of the _____ as part of the *Trail Managed and Maintained by* information section.

The _____'s phone number _____
_____ should
_____ should not
appear as a resource in the event of an emergency.

Name: _____ Title: _____

Signature: _____ Date: _____

Local Land Manager (adjacent to community or at trailhead)

I, _____, am responsible for input in and approval of kiosk panel content, including the permission to use the agency or organization logo, and the applicability of relevant emergency contact information.
Name: _____ Title: _____
Signature: _____ Date: _____
Agency: _____

The (name of kiosk project) has been reviewed by the _____ (agency name).

This content of the kiosk
_____ does
_____ does not
have approval to carry the logo of the _____ as part of the *Trail Managed and Maintained by* information section.

The _____'s phone number _____
_____ should
_____ should not
appear as a resource in the event of an emergency.

Name: _____ Title: _____

Signature: _____ Date: _____

Local A.T. Club

I, _____, am responsible for input in and approval of kiosk panel content, including the permission to use the agency or organization logo, and the applicability of relevant emergency contact information.
Name: _____ Title: _____
Signature: _____ Date: _____
Club: _____

The (name of kiosk project) has been reviewed by the _____.
This content of the kiosk
_____ does
_____ does not
have approval to carry the logo of the _____ as part of the *Trail Managed and Maintained by* information section.

Name: _____ Title: _____
Signature: _____ Date: _____

Local A.T. Club

I, _____, am responsible for input in and approval of kiosk panel content, including the permission to use the agency or organization logo, and the applicability of relevant emergency contact information.
Name: _____ Title: _____
Signature: _____ Date: _____
Club: _____

The (name of kiosk project) has been reviewed by the _____.
This content of the kiosk
_____ does
_____ does not
have approval to carry the logo of the _____ as part of the *Trail Managed and Maintained by* information section.

Name: _____ Title: _____
Signature: _____ Date: _____

Local Municipality

I, _____, am responsible for input in and approval of kiosk panel content, including the applicability of relevant emergency contact information.
Name: _____ Title: _____
Signature: _____ Date: _____
Municipality: _____

The (name of kiosk project) has been reviewed and approved by the _____.

The appropriate emergency contact phone number that should be listed for in the event of an emergency is _____.

Name: _____ Title: _____

Signature: _____ Date: _____

Kiosk Content Checklist

Indicate where each content item will be presented by placing “X” in the appropriate box; leave boxes blank when you do not intend to include this item.

Strongly Recommended Content Items

Panel	Bulletin Board	Content Item
		ANST Logo or Who Manages the Trail
		Welcome to the Appalachian Trail
		Map of the Trail in the area
		Emergency Contact Information
		Leave No Trace

Recommended Content

Panel	Bulletin Board	Content Item																		
		Regulatory Sign(s) (select which ones below) <table border="1" style="width: 100%; margin-top: 5px;"> <tr><td><input type="checkbox"/></td><td>No Hunting</td></tr> <tr><td><input type="checkbox"/></td><td>No Fires</td></tr> <tr><td><input type="checkbox"/></td><td>No Camping</td></tr> <tr><td><input type="checkbox"/></td><td>No Horses</td></tr> <tr><td><input type="checkbox"/></td><td>No Bikes</td></tr> <tr><td><input type="checkbox"/></td><td>Appropriate group size</td></tr> <tr><td><input type="checkbox"/></td><td>Other:</td></tr> <tr><td><input type="checkbox"/></td><td>Other:</td></tr> <tr><td><input type="checkbox"/></td><td></td></tr> </table>	<input type="checkbox"/>	No Hunting	<input type="checkbox"/>	No Fires	<input type="checkbox"/>	No Camping	<input type="checkbox"/>	No Horses	<input type="checkbox"/>	No Bikes	<input type="checkbox"/>	Appropriate group size	<input type="checkbox"/>	Other:	<input type="checkbox"/>	Other:	<input type="checkbox"/>	
<input type="checkbox"/>	No Hunting																			
<input type="checkbox"/>	No Fires																			
<input type="checkbox"/>	No Camping																			
<input type="checkbox"/>	No Horses																			
<input type="checkbox"/>	No Bikes																			
<input type="checkbox"/>	Appropriate group size																			
<input type="checkbox"/>	Other:																			
<input type="checkbox"/>	Other:																			
<input type="checkbox"/>																				
		Basic Safety / Education (select which ones) <table border="1" style="width: 100%; margin-top: 5px;"> <tr><td><input type="checkbox"/></td><td>What to take on a day hike</td></tr> <tr><td><input type="checkbox"/></td><td>Water Treatment Advisory</td></tr> <tr><td><input type="checkbox"/></td><td>Weather – lightning, etc</td></tr> <tr><td><input type="checkbox"/></td><td>Wildlife – ticks, bears, snakes</td></tr> <tr><td><input type="checkbox"/></td><td>Hunting regulations</td></tr> <tr><td><input type="checkbox"/></td><td>Other:</td></tr> <tr><td><input type="checkbox"/></td><td>Other:</td></tr> <tr><td><input type="checkbox"/></td><td></td></tr> </table>	<input type="checkbox"/>	What to take on a day hike	<input type="checkbox"/>	Water Treatment Advisory	<input type="checkbox"/>	Weather – lightning, etc	<input type="checkbox"/>	Wildlife – ticks, bears, snakes	<input type="checkbox"/>	Hunting regulations	<input type="checkbox"/>	Other:	<input type="checkbox"/>	Other:	<input type="checkbox"/>			
<input type="checkbox"/>	What to take on a day hike																			
<input type="checkbox"/>	Water Treatment Advisory																			
<input type="checkbox"/>	Weather – lightning, etc																			
<input type="checkbox"/>	Wildlife – ticks, bears, snakes																			
<input type="checkbox"/>	Hunting regulations																			
<input type="checkbox"/>	Other:																			
<input type="checkbox"/>	Other:																			
<input type="checkbox"/>																				
		Basic Trail Description																		
		Distances to Springer Mtn., Georgia and Katahdin, Maine																		
		Available space for dynamic content																		

Optional Content

Panel	Bulletin Board	Content Item
		Interpretive Information
		Technology Enhancements
		Supplemental Information
		Signs from partners like ALDHA encouraging considerate behavior in towns.

Trailhead Kiosk Quarterly Review Worksheet

This worksheet, completed by maintainers at least twice a year and submitted to the club's A.T. manager will help management partners prioritize kiosk structure and content updates. A photo of the kiosk should be submitted along with this report at least once per year.

Date:

Review performed by: _____

Check this box if a photo accompanies this report.

Condition of structure (circle one)

Excellent Good Fair Poor

Notes:

Condition of panel (circle one)

Excellent Good Fair Poor N/A

Notes:

Condition of information on bulletin board (circle one)

Excellent Good Fair Poor

Notes:

List items posted to bulletin board.

What issues have faced maintainers in this area that may be addressed with messages here?

Are there upcoming relocations, prescribed burns, or other scheduled management strategies for this area?

If so, what is the start date?

When should updates be posted to the dynamic content area of the kiosk?

Are there changes to ATC, NPS, USDA Forest Service, or other land manager's policies that affect this area or this kiosk?

ATC Leave No Trace Posting Guidelines

Clubs and agency partners can access copies of the Leave No Trace posters and updates to the posting guidelines at <http://atleavenotrace.wikispaces.com>

Local Management Planning Guide, Chapter 3 (E) Sign Policy

Traditionally, ATC has encouraged the use of simple directional signs, in addition to blazing, to help hikers find their way and locate side trails, shelters, and drinking-water supplies. Informational and regulatory signs are used to inform hikers, Trail neighbors, and potential trespassers about restrictions that apply on the Appalachian Trail and corridor lands. Good planning can ensure that a sign system conveys the necessary information in a pleasing, unobtrusive manner.

“Sign pollution,” in which there are more signs than necessary to direct and inform hikers and other users of the Trail lands should be avoided. Trailhead signs, which are usually appropriate at major Trailheads, can convey a significant amount of information to users without causing sign pollution. The other extreme also may cause problems: too few signs leave hikers and others inadequately informed.

Existing Policy

ATC Policy—ATC provides guidance on planning and establishing a sign system for the footpath in *Appalachian Trail Design, Construction and Maintenance*. ATC also has a booklet entitled *Planning and Building an Appalachian Trailhead Bulletin Board*, [replaced by this current document], which provides detailed guidance and plans for designing and constructing a Trailhead bulletin board.

The NPS delegation of management responsibility for A.T. corridor lands has necessitated regulatory signs to advise hikers, Trail neighbors and others about permitted and prohibited uses. Standard signs bearing basic user information and restrictions to aid Trail clubs in protecting corridor lands are available from ATC and may be ordered at no charge to the Trail-maintaining clubs from ATC’s *Appalachian Trail Corridor Management Signs* catalog (Appendix N). Many of the signs are suitable for use on other lands as well, provided the local Trail-maintaining club and agency partner agree that the signs are appropriate. The following guidelines for developing or posting signs on A.T. lands were endorsed by ATC’s Trail and Land Management Committee in March 1995:

Identify the club’s needs for signs as part of the Trail-assessment or local management-planning process. It is important to consider alternative methods for conveying information, such as brochures, registers, or personal contacts.

Be certain that signs containing the National Park Service’s official arrowhead symbol are placed only on National Park Service lands.

Comply with state and local legal requirements for posting property.

Locate signs conspicuously, but not too conspicuously. Signs directed at Trail users will be less prone to vandalism if placed on the Trail, but just out of sight of roads. Signs that convey messages to others will be most effective if posted along roads and at other potential points of entry.

Avoid “sign pollution” by using only the minimum needed to do the job. If you need to convey more than one or two messages, consider using a Trailhead signboard or small “birdhouse” to post signs on.

Monitor signs regularly for damage, disappearance, and effectiveness. It helps to have a master sign list and inventory so that signs can be replaced when needed.

If you need to develop additional signs, consider the following:

- a) Your greeting should be friendly but authoritative.
- b) Identify the Trail club and land-managing agency where appropriate.
- c) State prohibitions or restrictions in a positive way.
- d) Include names and phone numbers of emergency contacts where appropriate.
- e) Use international symbols where appropriate.
- f) The wording of regulatory signs or the use of the symbol of any land-managing agency *needs to be approved* by the land-managing agency.
- g) Posting of specific prohibitions, such as NO HUNTING or NO HORSES, requires a reference to the pertinent regulation to be properly enforced.

NPS Policy—The A.T. Park Office should be consulted about major signs at road intersections and Trailheads that identify the Appalachian National Scenic Trail to the general public. That office has approved the wording of signs listed in ATC’s *Appalachian Trail Corridor Management Signs* catalog (Appendix N).

The National Park Service has developed extensive sign standards that are usually applied within existing national parks. Signs should be limited to the minimum necessary to provide information, warning, and regulatory needs and avoid confusion and visual intrusion. However, the agency also has endorsed the use of club directional signs along some sections of the Trail. Trail-maintaining clubs with Trail sections within units of the National Park system need to work with park managers to ensure a high-quality system within park boundaries that adequately serves A.T. users (section 9.2.3 of 2006 NPS *Management Policies*).

In designated wilderness areas on National Park Service lands, only necessary signs intended for visitor safety, such as route direction and distances, should be

posted. When signs are posted, they should be minimal in size and be compatible with the surrounding area (section 6.3.10.4 of 2006 NPS *Management Policies*).

Considerations for Planning

Inventory—Many Trail clubs maintain an inventory of existing signs along the footpath of the Appalachian Trail. A master list can be developed or updated during a “walk-through” or Trail assessment.

Setting Trail Club Policy—The Trail club should indicate the general situations that require signs and the standards that the club will apply for their design, construction, and use. Regulations regarding wording and use of agency logos should be discussed with the land-managing agency prior to developing or posting signs.

Action Plan—Many Trail clubs already have individuals or sign committees in place who are familiar with existing needs and who maintain a list of signs that are needed. This list should be included in the local management plan and updated as part of the annual work plan. At Trailheads, posted information such as regulations and education material should be accurate and concise, and attractively displayed on some form of bulletin board. Bulletin boards should be checked at least annually.

Local Management Planning Guide, Chapter 3 (G) Advertising Policy

Advertising in the A.T. Corridor

Hostels, shuttle services, restaurants, and other services that cater to hikers have “advertised” in some fashion for years. Many of these businesses are noted in the A.T. Thru-Hikers’ Companion (published by ATC, with authorship rights held by the Appalachian Long Distance Hikers Association) and other such guides that are updated annually. Advertisements and signs are sometimes posted in the Trail corridor. Shelter registers often contain entries describing the services offered in nearby towns. It has become more common to find business cards for nearby businesses in shelters or attached to Trailhead signs.

ATC and its partners have responded by clarifying direction regarding advertising on A.T. corridor lands. In line with the position stated in the A.T. Comprehensive Plan and long-standing NPS and USFS policies that prohibit advertising for commercial enterprises located outside park or forest boundaries, advertisements found on Trail corridor lands should be removed with prior notification to partner agencies.

The services provided to hikers by commercial businesses are valuable, and reliance on some of those services (such as hostels) have always been accepted as part of the Trail experience. In Maine, for example, the Trail originally passed a number of sporting camps that were considered part of the overnight accommodation system of the A.T. in the late 1930s and 1940s. Long-distance hikers in particular should be able to access information about services available in nearby communities. Appropriate ways of disseminating this information without affecting the natural and remote character of the A.T. must be found.

Existing Policy

ATC Policy—In 2001 the ATC Board adopted the following policy on advertising in the A.T. corridor:

The Appalachian Trail Conservancy places a high value on maintaining the natural character of the Appalachian Trail corridor and is well-aware that small changes diminish that character can cumulatively alter the Trail environment to the point where the A.T. is no longer a simple footpath passing through a natural setting. Those principles are embodied in numerous ATC policies.

At the same time, ATC recognizes that many A.T. hikers value the services (e.g. lodging, restaurants, outfitters, and shuttles) that are available in many communities along the Trail. Those services may be commercial in nature or offered by Trail enthusiasts acting on their own initiatives, who provide free or for-cost assistance to hikers. Both commercial businesses and Trail enthusiasts make significant contributions to the over-all experience of hiking the A.T. and are important to many hikers, especially long-distance hikers.

Both the National Park Service and the Forest Service prohibit advertising on federal lands. ATC and the clubs should take steps to ensure those longstanding prohibitions in federal regulations are clearly disseminated, implemented, and understood by hikers, Trail neighbors, and affected area businesses or individuals.

In order to maintain the natural character of the A.T. corridor, it is the policy of the Appalachian Trail Conservancy that advertising is incompatible with the Trail and should not take place within the A.T. corridor. Furthermore, ATC and the clubs should urge the adoption of regulations prohibiting on-site advertising by states and municipalities that control Trail lands where such regulations do not now exist. If necessary, the availability of hiker services outside of the Trail corridor should be publicized through other means, such as publications and Trailhead signs.

For the purpose of this policy, advertising is designed as posting materials, such as signs, notes, or business cards, or distributing flyers, brochures, or similar materials designed to call specific services, both commercial and

noncommercial, to the attention of hikers. Materials that promote membership in the ATC or Trail-maintaining clubs or participation in volunteer Trail-management activities and materials that recognize the donations of commercial or noncommercial entities for the A.T. are not included in this definition.

NPS Policy—Commercial notices or advertisements generally will not be displayed, posted, or distributed on the federally owned or federally controlled land, water, or airspace of a park (section 9.3.5 of the 2006 NPS Management Policies).

Considerations for Planning

Inventory—No inventory is necessary.

Setting Trail Club Policy—In developing a policy on advertising, Trail clubs should emphasize the need to keep advertisements out of the Trail corridor, and identify strategies to this end. Strategies could include lobbying for the adoption of municipal and/or state regulations restricting advertising on Trail lands, providing alternative advertising solutions to local service providers, and any other means deemed appropriate by individual clubs.

Action Plan—Trail clubs may develop action plans to implement the strategies identified in their policy.

ⁱ Birchard, William, Proudman, Robert, *Appalachian Trail Design, Construction, and Maintenance*, Second Edition, Harpers Ferry, WV, 2000, pg 169

ⁱⁱ LMPG 2009, Signs 3(E), pg. 87

ⁱⁱⁱ Birchard, William, Proudman, Robert, *Appalachian Trail Design, Construction, and Maintenance*, Second Edition, Harpers Ferry, WV, 2000, pg. 15

EXAMPLE OF SIGN ON NATIONAL PARK SERVICE



Harpers Ferry-Bolivar

VISITOR SERVICES



Robert Harper, Thomas Jefferson, Meriwether Lewis, John Brown, Stonewall Jackson, W.B. Du Bois, and Frederick Douglass all visited Harpers Ferry/Bolivar—and now you! We hope you enjoy your visit to our historic towns at this gap in the Blue Ridge. Take a hike or a bike ride, float down the rivers, visit Harpers Ferry National Historical Park, and explore our unique and friendly shops.

Dining and refreshments are available throughout the lower town and along Washington Street in Bolivar. A variety of accommodations is available for those staying overnight. The lower town has a historic inn, Bolivar has a hostel, and bed and breakfasts are sprinkled throughout the two towns. Motels and campgrounds are on or just off nearby US 340.

Outstanding trails, including the world-famous Appalachian Trail, offer memorable views and the opportunity to learn about our nation's history while getting some fresh air. Outfitters and guides in and around Harpers Ferry offer guided trips or rentals for those interested in fishing, horse or bike trails, zip lines, river trips, exploring our history, or even hearing about our resident ghosts!

More information for visitors is available at the Jefferson County Visitors Bureau in Bolivar, from the Appalachian Trail Conservancy in the upper town of Harpers Ferry, and from National Park information centers on US 340 and in the lower town. When you are ready to leave, Amtrak, the MARC commuter train, PANTRAN bus service, taxis, car rentals, shuttle services, highways and trails all provide connections to other places. But we hope you'll return to discover more of our towns and our beautiful region.



C&O Canal and Towpath Trail



----- C & O Canal Towpath (NPS)
(The Potomac Heritage National Scenic Trail follows the towpath and now Harpers Ferry)

----- Appalachian Trail

Police	United States Post Office
Fire, EMS	Medical center
Information center	Information kiosk
Parking	Shopping
Public restrooms	Scenic views
ATM	Library
Hotel, bed & breakfast	Dining
Hostel	Groceries
Camping	Hiking





Access current Harpers Ferry merchant and Canal Towns information on your mobile phone.

This information panel was made possible through contributions from CSX Corporation Inc. and the National Park Service.